

TITLE :-
HOUSE WATER SUPPLY LAYOUT PLAN SHOWING
FOR G+5 STD. BUILDING.

OWNER :-
SRI , SARJU SHARMA , S/O LATE JAGDISH
PRASAD SHARMA RESIDENCE OF SHASTRI
NAGAR, WARD NO.-41(S.M.C.), P.O.-
SEVOKE ROAD, P.S.- BHAKTINAGAR , DIST-
JALPAIGURI, PIN-734001, WEST BENGAL.

LOCATION :-
SHASTRI NAGAR , WARD NO.-41(S.M.C)

SCHEDULE OF LAND :-
MOUZA - DABGRAM,
L.R. PLOT NO. - 40 (P), 41
R.S PLOT NO.- 558, 559, 460
SHEET NO. 08 (R.S) . 40 (L.R)
L.R KHATIAN NO. - 160,162
R.S KHATIAN NO. - 319,320,150
J.L. No. - 2,
P,S. BHAKTINAGAR ,
DIST. - JALPAIGURI
WARD NO. - 41 (SMC)

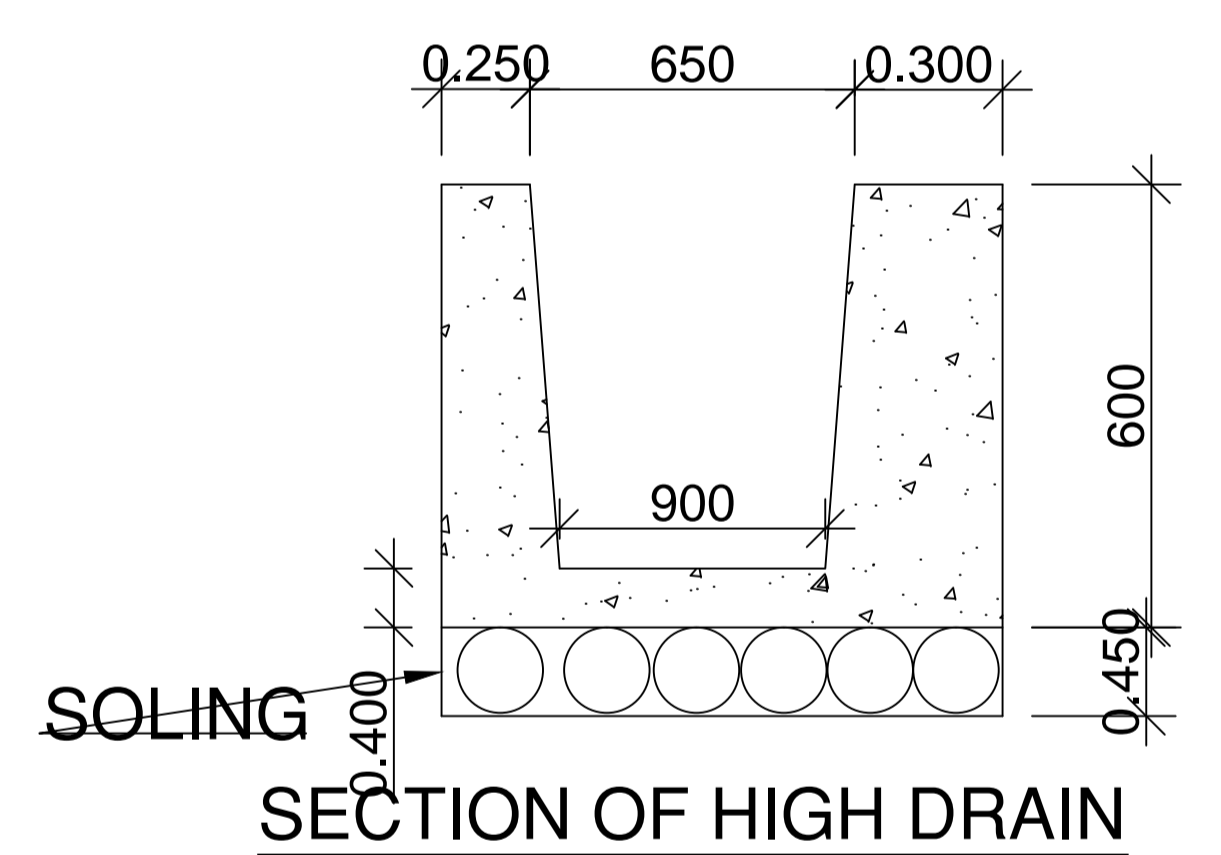
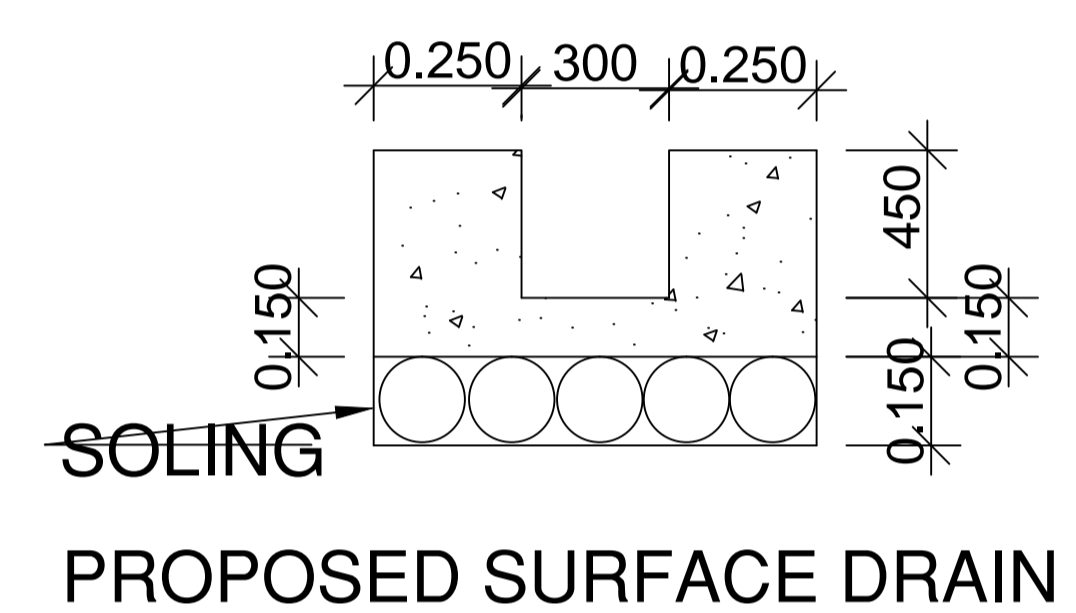
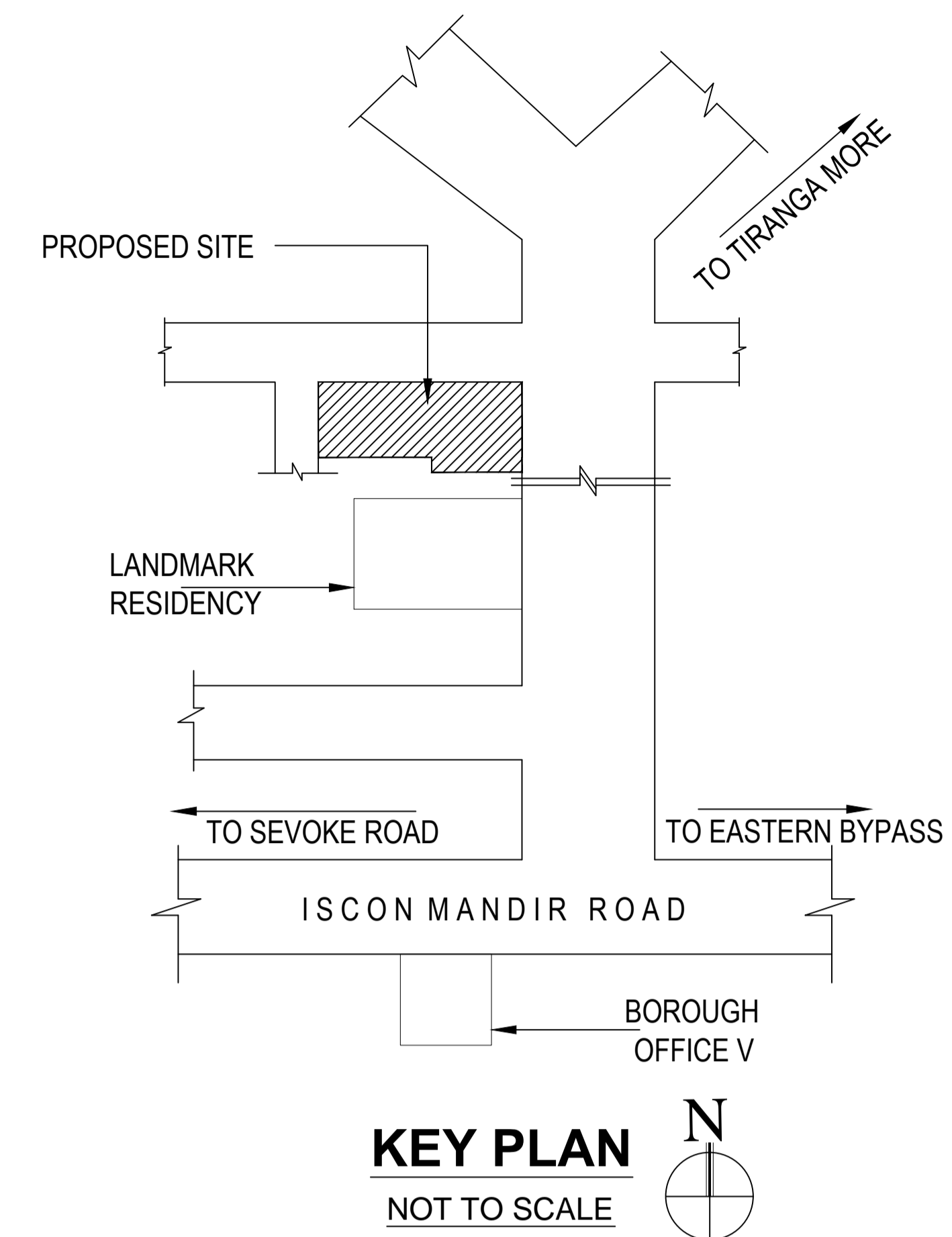
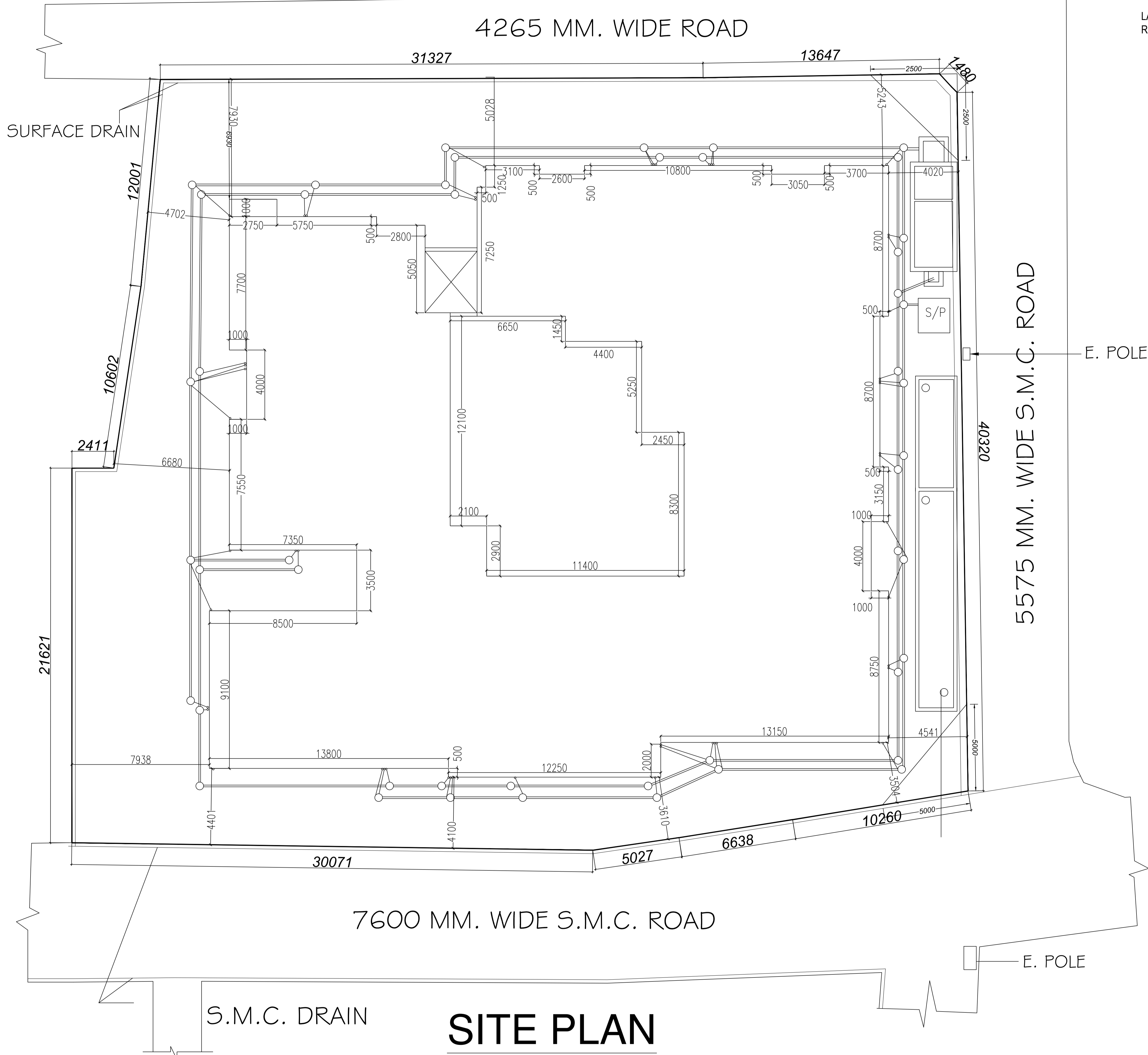

**WASTE WATER DISCHARGE
CALCULATION**

THIS IS TO STATE THAT THE WASTE WATER
RECYCLING SYSTEM WILL NOT BE REQUIRED
FOR THE FOLLOWING BUILDING AS THE
TOTAL WASTE WATER DISCHARGE IS LESS
THAN 40,000 LTRS. PER DAY. CONSIDERING
DISCHARGE WATER = 5 (PERSONS) X 130
LTR.X 40 (TENEMENTS) = 26000 LTRS.

**TREE COVER
CALCULATION**

PERMISSIBLE:
 $(2161.39 \times 5420.02 \times 15\%) / 6000$
 $= 292.86 \text{ SQ.M. (13.55\%)}$
PROPOSED:
COVER AREA (1) : 154.19 SQ.M.
COVER AREA (2) : 173.62 SQ.M.
COVER AREA (3) : 10.97 SQ.M.
TOTAL (15.67%) : 338.78 SQ.M.

AREA STATEMENTS :-

PARAMETER	MIN. REQUIRED	MAX. PERMISSIBLE	PROVIDED
BUILDING HEIGHT	N.A.	20.00 M	20.00 M
FAR	N.A.	2.00	1.99
GROUND COVERAGE(IN %)	N.A.	50.00	38.45
PLOT AREA	N.A.	N.A.	2161.39 M ²
MINIMUM WIDTH OF PLOT	N.A.	N.A.	52.00 M
TOTAL BUILTUP AREA	N.A.	N.A.	5341.45 M ²
FLOOR AREA (FOR F.A.R.)	N.A.	4322.78 M ²	4302.33 M ²
COVERED AREA	N.A.	1080.70 M ²	831.10 M ²
TOTAL NO. OF TENEMENTS	N.A.	N.A.	40 NOS.
TOTAL NO. OF PARKING	33 NOS	N.A.	35 NOS
MERCANTILE RETAIL AREA			146.83 M ²

